

Dual 135 μ A, 14nV/ $\sqrt{\text{Hz}}$, Rail-to-Rail Output Precision Op Amp

FEATURES

- 75 μ V Maximum Offset Voltage
- 900pA Maximum Input Bias Current
- 135 μ A Supply Current per Amplifier
- Rail-to-Rail Output Swing
- 120dB Minimum Voltage Gain, $V_S = \pm 15\text{V}$
- 0.8 $\mu\text{V}/^\circ\text{C}$ Maximum V_{OS} Drift
- 14nV/ $\sqrt{\text{Hz}}$ Input Noise Voltage
- 0.4 $\mu\text{V}/\text{Month}$ Long-Term V_{OS} Stability
- 2.7V to $\pm 18\text{V}$ Supply Voltage Operation
- Space Saving 3mm \times 3mm DFN Package
- Operating Temperature Range: -40°C to 85°C

APPLICATIONS

- Thermocouple Amplifiers
- Precision Photo Diode Amplifiers
- Instrumentation Amplifiers
- Battery-Powered Precision Systems

DESCRIPTION

The LT[®]6011 dual op amp combines low noise and high precision input performance with low power consumption and rail-to-rail output swing.

Input offset voltage is trimmed to less than 75 μV . The low drift and excellent long-term stability guarantee a high accuracy over temperature and time. The 900pA maximum input bias current and 120dB minimum voltage gain further maintain this precision over operating conditions.

The LT6011 works on any power supply voltage from 2.7V to 36V and draws only 135 μA of supply current on a 5V supply. The output voltage swings to within 40mV of either supply rail, making the amplifier a good choice for low voltage single supply operation.

The LT6011 is fully specified at 5V and $\pm 15\text{V}$ supplies and from -40°C to 85°C . The device is available in SO-8 and space saving 3mm \times 3mm DFN packages.

LT, LTC and LT are registered trademarks of Linear Technology Corporation. SoftSpan is a trademark of Linear Technology Corporation.

TYPICAL APPLICATION

Low Power Programmable Output Range 16-Bit SoftSpan[™] DAC

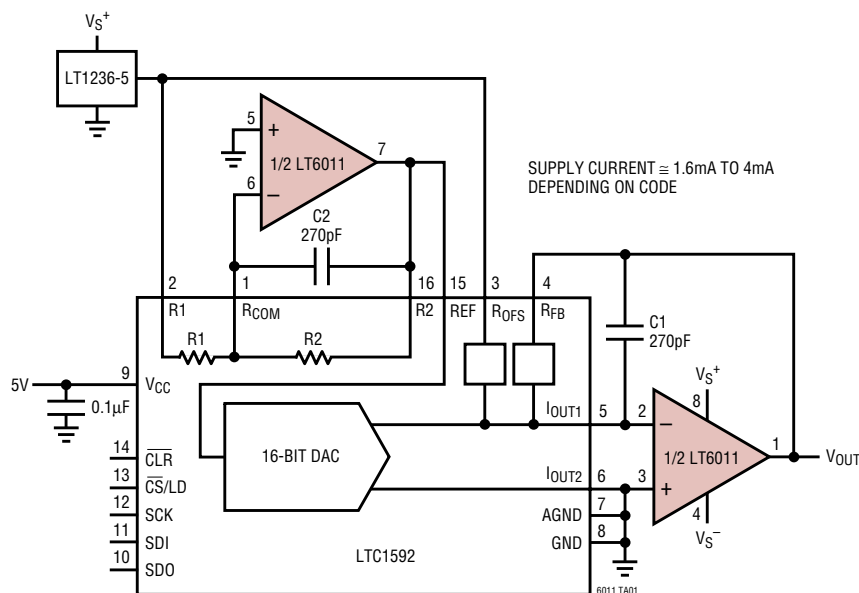

20V Output Step Response

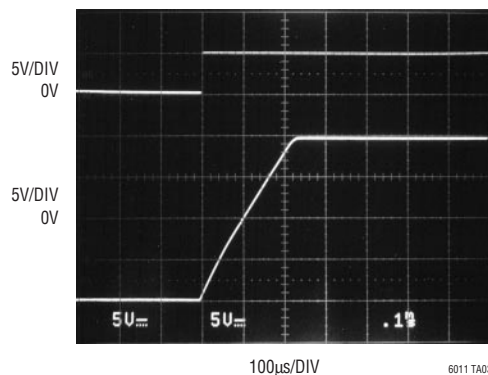

6011 TA03

6011f

ABSOLUTE MAXIMUM RATINGS (Note 1)

Total Supply Voltage (V^+ to V^-)	40V	Maximum Junction Temperature	
Differential Input Voltage (Note 2)	10V	DD Package	125°C
Input Voltage	V^+ to V^-	SO-8 Package	150°C
Input Current (Note 2)	$\pm 10\text{mA}$	Storage Temperature Range	
Output Short-Circuit Duration (Note 3)	Indefinite	DD Package	-65°C to 125°C
Operating Temperature Range (Note 4) ..	-40°C to 85°C	SO-8 Package	-65°C to 150°C
Specified Temperature Range (Note 5) ...	-40°C to 85°C	Lead Temperature (Soldering, 10 sec)	300°C

PACKAGE/ORDER INFORMATION

<p>DD PACKAGE 8-LEAD (3mm x 3mm) PLASTIC DFN $T_{JMAX} = 125^\circ\text{C}$, $\theta_{JA} = 160^\circ\text{C/W}$ UNDERSIDE METAL CONNECTED TO V^-</p>	ORDER PART NUMBER	<p>S8 PACKAGE 8-LEAD PLASTIC SO $T_{JMAX} = 150^\circ\text{C}$, $\theta_{JA} = 190^\circ\text{C/W}$</p>	ORDER PART NUMBER
	LT6011CDD LT6011IDD		LT6011CS8 LT6011IS8
	DD PART MARKING*		S8 PART MARKING
	LACD		6011 6011I

*Temperature grades are identified by a label on the shipping container.
Consult LTC Marketing for parts specified with wider operating temperature ranges.

ELECTRICAL CHARACTERISTICS

The ● denotes the specifications which apply over the full operating temperature range, otherwise specifications are at $T_A = 25^\circ\text{C}$. $V_S = 5\text{V}$, 0V ; $V_{CM} = 2.5\text{V}$; R_L to 0V ; unless otherwise specified. (Note 5)

SYMBOL	PARAMETER	CONDITIONS	MIN	TYP	MAX	UNITS
V_{OS}	Input Offset Voltage	LT6011S8		25	75	μV
		$T_A = 0^\circ\text{C}$ to 70°C	●		100	μV
		$T_A = -40^\circ\text{C}$ to 85°C	●		125	μV
		LT6011DD		25	125	μV
		$T_A = 0^\circ\text{C}$ to 70°C	●		175	μV
		$T_A = -40^\circ\text{C}$ to 85°C	●		210	μV
$\Delta V_{OS}/\Delta T$	Input Offset Voltage Drift (Note 6)	LT6011S8	●	0.2	0.8	$\mu\text{V}/^\circ\text{C}$
		LT6011DD	●	0.2	1.3	$\mu\text{V}/^\circ\text{C}$
I_{OS}	Input Offset Current			150	900	pA
		$T_A = 0^\circ\text{C}$ to 70°C	●		1200	pA
		$T_A = -40^\circ\text{C}$ to 85°C	●		1500	pA
I_B	Input Bias Current			± 150	± 900	pA
		$T_A = 0^\circ\text{C}$ to 70°C	●		± 1200	pA
		$T_A = -40^\circ\text{C}$ to 85°C	●		± 1500	pA
	Input Noise Voltage	0.1Hz to 10Hz		400		nV_{P-P}
e_n	Input Noise Voltage Density	$f = 1\text{kHz}$		14		$\text{nV}/\sqrt{\text{Hz}}$
i_n	Input Noise Current Density	$f = 1\text{kHz}$		0.1		$\text{pA}/\sqrt{\text{Hz}}$
R_{IN}	Input Resistance	Common Mode, $V_{CM} = 1\text{V}$ to 3.8V	10	120		$\text{G}\Omega$
		Differential		20		$\text{M}\Omega$

6011f

ELECTRICAL CHARACTERISTICS The ● denotes the specifications which apply over the full operating temperature range, otherwise specifications are at $T_A = 25^\circ\text{C}$. $V_S = 5\text{V}$, 0V ; $V_{CM} = 2.5\text{V}$; R_L to 0V ; unless otherwise specified. (Note 5)

SYMBOL	PARAMETER	CONDITIONS	MIN	TYP	MAX	UNITS
C_{IN}	Input Capacitance			4		pF
V_{CM}	Input Voltage Range (Positive)	Guaranteed by CMRR	● 3.8	4		V
	Input Voltage Range (Negative)	Guaranteed by CMRR	●	0.7	1	V
CMRR	Common Mode Rejection Ratio	$V_{CM} = 1\text{V to } 3.8\text{V}$	● 107	135		dB
	Minimum Supply Voltage	Guaranteed by PSRR	●	2.4	2.7	V
PSRR	Power Supply Rejection Ratio	$V_S = 2.7\text{V to } 36\text{V}$, $V_{CM} = 1/2V_S$	● 112	135		dB
A_{VOL}	Large-Signal Voltage Gain	$R_L = 10\text{k}$, $V_{OUT} = 1\text{V to } 4\text{V}$	● 300	2000		V/mV
		$R_L = 2\text{k}$, $V_{OUT} = 1\text{V to } 4\text{V}$	● 250	2000		V/mV
	Channel Separation	$V_{OUT} = 1\text{V to } 4\text{V}$	● 110	140		dB
V_{OUT}	Maximum Output Swing (Positive, Referred to V^+)	No Load, 50mV Overdrive	●	35	55	mV
		$I_{SOURCE} = 1\text{mA}$, 50mV Overdrive	●	120	170	mV
	Maximum Output Swing (Negative, Referred to 0V)	No Load, 50mV Overdrive	●	40	55	mV
		$I_{SINK} = 1\text{mA}$, 50mV Overdrive	●	150	225	mV
I_{SC}	Output Short-Circuit Current (Note 3)	$V_{OUT} = 0\text{V}$, 1V Overdrive, Source	● 10	14		mA
			4		mA	
		$V_{OUT} = 5\text{V}$, -1V Overdrive, Sink	● 10	21		mA
			4		mA	
SR	Slew Rate	$A_V = -10$, $R_F = 50\text{k}$, $R_G = 5\text{k}$	● 0.06	0.09		V/ μs
		$T_A = 0^\circ\text{C to } 70^\circ\text{C}$	● 0.05			V/ μs
		$T_A = -40^\circ\text{C to } 85^\circ\text{C}$	● 0.04			V/ μs
GBW	Gain Bandwidth Product	$f = 10\text{kHz}$	● 250	330		kHz
			225			kHz
t_s	Settling Time	$A_V = -1$, 0.01%, $V_{OUT} = 1.5\text{V to } 3.5\text{V}$		45		μs
t_r , t_f	Rise Time, Fall Time	$A_V = 1$, 10% to 90%, 0.1V Step		1		μs
ΔV_{OS}	Offset Voltage Match (Note 7)	LT6011S8	●	50	150	μV
		$T_A = 0^\circ\text{C to } 70^\circ\text{C}$	●		200	μV
		$T_A = -40^\circ\text{C to } 85^\circ\text{C}$	●		250	μV
		LT6011DD	●	50	250	μV
		$T_A = 0^\circ\text{C to } 70^\circ\text{C}$	●		350	μV
		$T_A = -40^\circ\text{C to } 85^\circ\text{C}$	●		420	μV
ΔI_B	Input Bias Current Match (Note 7)	$T_A = 0^\circ\text{C to } 70^\circ\text{C}$	●	250	1800	pA
		$T_A = -40^\circ\text{C to } 85^\circ\text{C}$	●		2400	pA
			●		3000	pA
ΔCMRR	Common Mode Rejection Ratio Match (Note 7)		● 101	135		dB
ΔPSRR	Power Supply Rejection Ratio Match (Note 7)		● 106	135		dB
I_S	Supply Current	per Amplifier	●	135	150	μA
		$T_A = 0^\circ\text{C to } 70^\circ\text{C}$	●		190	μA
		$T_A = -40^\circ\text{C to } 85^\circ\text{C}$	●		210	μA

ELECTRICAL CHARACTERISTICS The ● denotes the specifications which apply over the full operating temperature range, otherwise specifications are at $T_A = 25^\circ\text{C}$. $V_S = \pm 15\text{V}$, $V_{CM} = 0\text{V}$, R_L to 0V , unless otherwise specified. (Note 5)

SYMBOL	PARAMETER	CONDITIONS	MIN	TYP	MAX	UNITS
V_{OS}	Input Offset Voltage	LT6011S8		25	150	μV
		$T_A = 0^\circ\text{C}$ to 70°C	●		175	μV
		$T_A = -40^\circ\text{C}$ to 85°C	●		200	μV
		LT6011DD		25	200	μV
		$T_A = 0^\circ\text{C}$ to 70°C	●		250	μV
		$T_A = -40^\circ\text{C}$ to 85°C	●		275	μV
$\Delta V_{OS}/\Delta T$	Input Offset Voltage Drift (Note 6)	LT6011S8	●	0.2	0.8	$\mu\text{V}/^\circ\text{C}$
		LT6011DD	●	0.2	1.3	$\mu\text{V}/^\circ\text{C}$
I_{OS}	Input Offset Current			150	900	pA
		$T_A = 0^\circ\text{C}$ to 70°C	●		1200	pA
		$T_A = -40^\circ\text{C}$ to 85°C	●		1500	pA
I_B	Input Bias Current			± 150	± 900	pA
		$T_A = 0^\circ\text{C}$ to 70°C	●		± 1200	pA
		$T_A = -40^\circ\text{C}$ to 85°C	●		± 1500	pA
	Input Noise Voltage	0.1Hz to 10Hz		400		$\text{nV}_{\text{p-p}}$
e_n	Input Noise Voltage Density	$f = 1\text{kHz}$		13		$\text{nV}/\sqrt{\text{Hz}}$
i_n	Input Noise Current Density	$f = 1\text{kHz}$		0.1		$\text{pA}/\sqrt{\text{Hz}}$
R_{IN}	Input Resistance	Common Mode, $V_{CM} = \pm 13.5\text{V}$	50	400		$\text{G}\Omega$
		Differential		20		$\text{M}\Omega$
C_{IN}	Input Capacitance			4		pF
V_{CM}	Input Voltage Range	Guaranteed by CMRR	● ± 13.5	± 14		V
CMRR	Common Mode Rejection Ratio	$V_{CM} = -13.5\text{V}$ to 13.5V	● 115	135		dB
	Minimum Supply Voltage	Guaranteed by PSRR	●	± 1.2	± 1.35	V
PSRR	Power Supply Rejection Ratio	$V_S = \pm 1.35\text{V}$ to $\pm 18\text{V}$	● 112	135		dB
A_{VOL}	Large-Signal Voltage Gain	$R_L = 10\text{k}$, $V_{OUT} = -13.5\text{V}$ to 13.5V	● 1000	2000		V/mV
			● 600			V/mV
		$R_L = 5\text{k}$, $V_{OUT} = -13.5\text{V}$ to 13.5V	● 500	1500		V/mV
			● 300			V/mV
	Channel Separation	$V_{OUT} = -13.5\text{V}$ to 13.5V	● 120	140		dB
V_{OUT}	Maximum Output Swing (Positive, Referred to V^+)	No Load, 50mV Overdrive	●	45	80	mV
			●		100	mV
	Maximum Output Swing (Negative, Referred to V^-)	$I_{SOURCE} = 1\text{mA}$, 50mV Overdrive	●	140	195	mV
			●		240	mV
I_{SC}	Output Short-Circuit Current (Note 3)	No Load, 50mV Overdrive	●	45	80	mV
			●		100	mV
		$I_{SINK} = 1\text{mA}$, 50mV Overdrive	●	150	250	mV
			●		300	mV
I_{SC}	Output Short-Circuit Current (Note 3)	$V_{OUT} = 0\text{V}$, 1V Overdrive (Source)	●	10	15	mA
			●	5		mA
I_{SC}	Output Short-Circuit Current (Note 3)	$V_{OUT} = 0\text{V}$, -1V Overdrive (Sink)	●	10	20	mA
			●	5		mA
SR	Slew Rate	$A_V = -10$, $R_F = 50\text{k}$, $R_G = 5\text{k}$	●	0.08	0.11	$\text{V}/\mu\text{s}$
		$T_A = 0^\circ\text{C}$ to 70°C	●	0.07		$\text{V}/\mu\text{s}$
		$T_A = -40^\circ\text{C}$ to 85°C	●	0.05		$\text{V}/\mu\text{s}$

ELECTRICAL CHARACTERISTICS The ● denotes the specifications which apply over the full operating temperature range, otherwise specifications are at $T_A = 25^\circ\text{C}$. $V_S = \pm 15\text{V}$, $V_{CM} = 0\text{V}$, R_L to 0V , unless otherwise specified. (Note 5)

SYMBOL	PARAMETER	CONDITIONS	MIN	TYP	MAX	UNITS
GBW	Gain Bandwidth Product	$f = 10\text{kHz}$	275 250	350		kHz kHz
t_s	Settling Time	$A_V = -1$, 0.01% , $V_{OUT} = 0\text{V}$ to 10V		85		μs
t_r , t_f	Rise Time, Fall Time	$A_V = 1$, 10% to 90% , 0.1V Step		1		μs
ΔV_{OS}	Offset Voltage Match (Note 7)	LT6011S8 $T_A = 0^\circ\text{C}$ to 70°C $T_A = -40^\circ\text{C}$ to 85°C	● ●	50	300 350 400	μV μV μV
		LT6011DD $T_A = 0^\circ\text{C}$ to 70°C $T_A = -40^\circ\text{C}$ to 85°C	● ●	50	400 500 550	μV μV μV
ΔI_B	Input Bias Current Match (Note 7)	$T_A = 0^\circ\text{C}$ to 70°C $T_A = -40^\circ\text{C}$ to 85°C	● ●	250	1800 2400 3000	pA pA pA
ΔCMRR	Common Mode Rejection Ratio Match (Note 7)		●	109	135	dB
ΔPSRR	Power Supply Rejection Ratio Match (Note 7)		●	106	135	dB
I_S	Supply Current	per Amplifier $T_A = 0^\circ\text{C}$ to 70°C $T_A = -40^\circ\text{C}$ to 85°C	● ●	260	330 380 400	μA μA μA

Note 1: Absolute Maximum Ratings are those beyond which the life of the device may be impaired.

Note 2: The inputs are protected by back-to-back diodes and internal series resistors. If the differential input voltage exceeds 10V , the input current must be limited to less than 10mA .

Note 3: A heat sink may be required to keep the junction temperature below absolute maximum ratings.

Note 4: Both the LT6011C and LT6011I are guaranteed functional over the operating temperature range of -40°C to 85°C .

Note 5: The LT6011C is guaranteed to meet the specified performance from 0°C to 70°C and is designed, characterized and expected to meet

specified performance from -40°C to 85°C but is not tested or QA sampled at these temperatures. The LT6011I is guaranteed to meet specified performance from -40°C to 85°C .

Note 6: This parameter is not 100% tested.

Note 7: Matching parameters are the difference between the two amplifiers. ΔCMRR and ΔPSRR are defined as follows: (1) CMRR and PSRR are measured in $\mu\text{V}/\text{V}$ for the individual amplifiers. (2) The difference between matching amplifiers is calculated in $\mu\text{V}/\text{V}$. (3) The result is converted to dB.

TYPICAL PERFORMANCE CHARACTERISTICS

Distribution of Input Offset Voltage

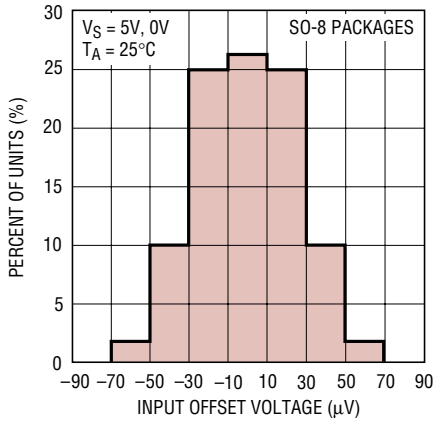

6011 G01

Input Offset Voltage vs Temperature

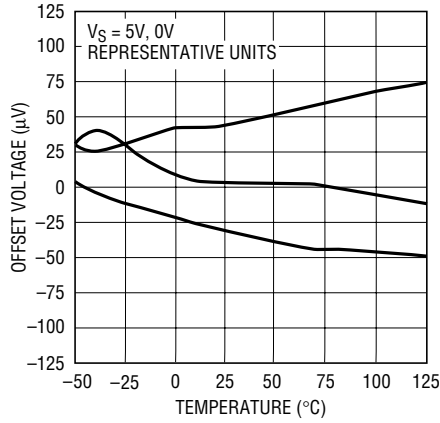

6011 G02

Offset Voltage vs Input Common Mode Voltage

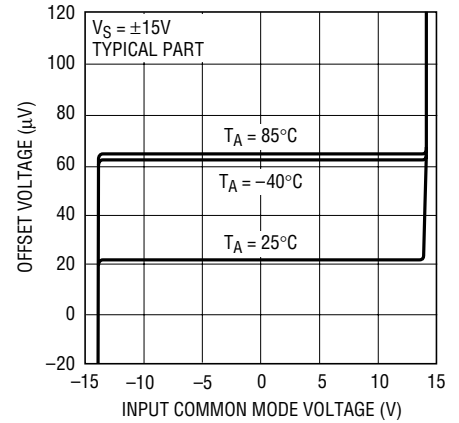

6011 G03

Input Bias Current vs Temperature

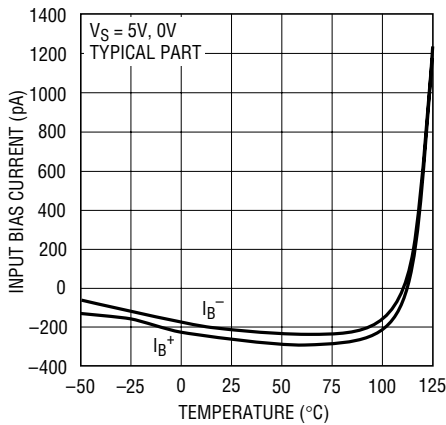

6011 G04

Input Bias Current vs Input Common Mode Voltage

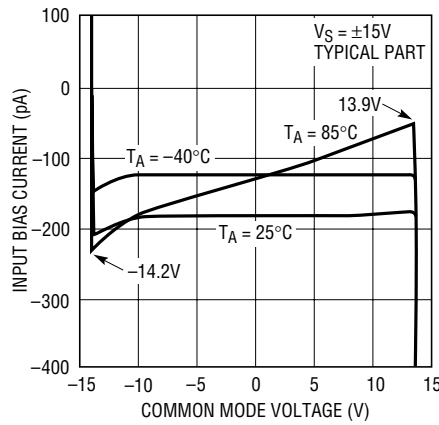

1635 G05

e_n, i_n vs Frequency

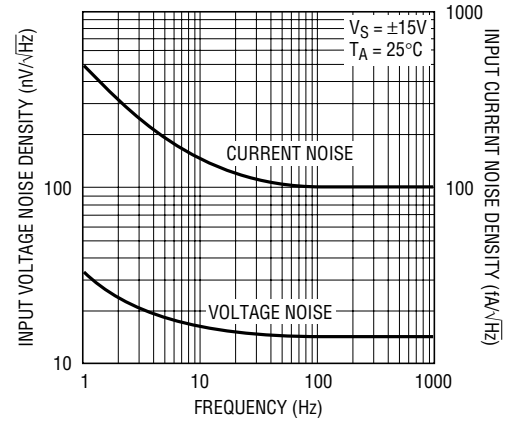

6011 G06

Total Input Noise vs Source Resistance

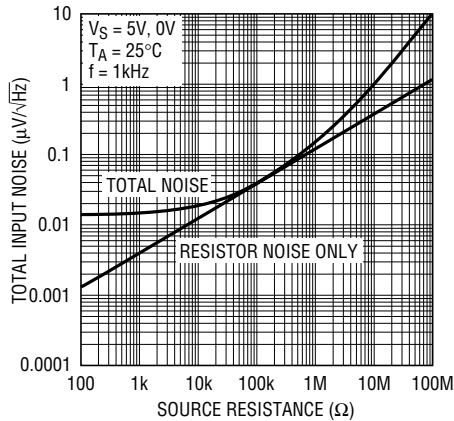

6011 G07

0.1Hz to 10Hz Noise

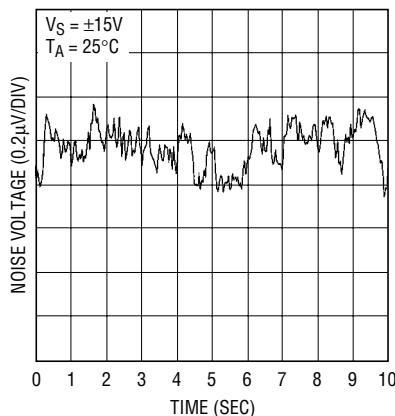

6011 G08

0.01Hz to 1Hz Noise

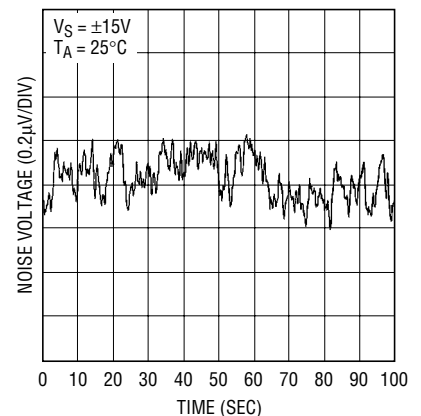

6011 G09

TYPICAL PERFORMANCE CHARACTERISTICS

Output Voltage Swing vs Temperature

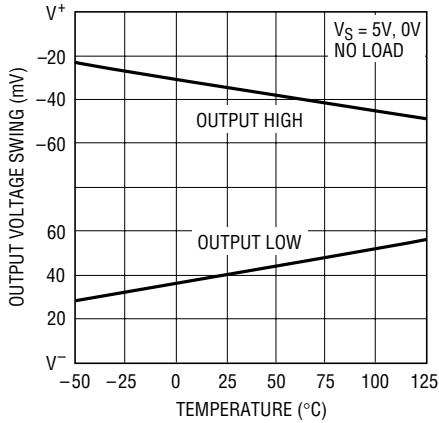

6011 G10

Output Saturation Voltage vs Load Current (Output High)

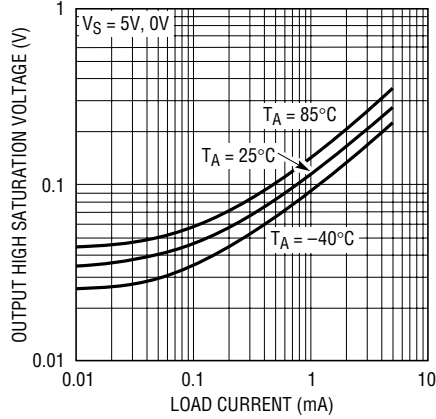

6011 G11

Output Saturation Voltage vs Load Current (Output Low)

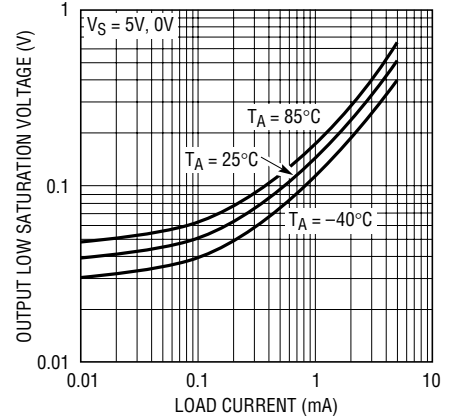

6011 G12

Supply Current vs Supply Voltage

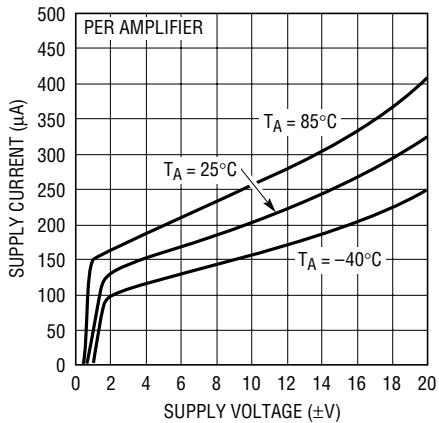

6011 G13

Warm-Up Drift

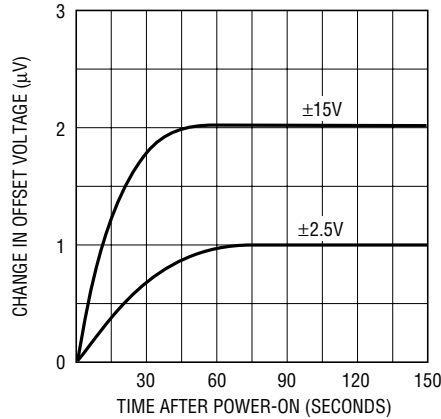

6011 G14

THD + Noise vs Frequency

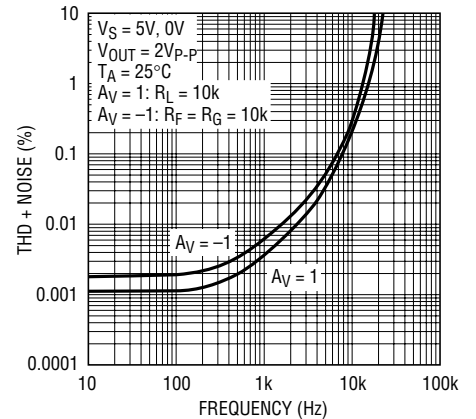

6011 G15

THD + Noise vs Frequency

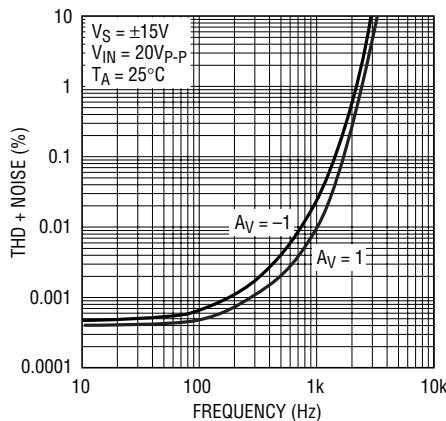

6011 G16

Settling Time vs Output Step

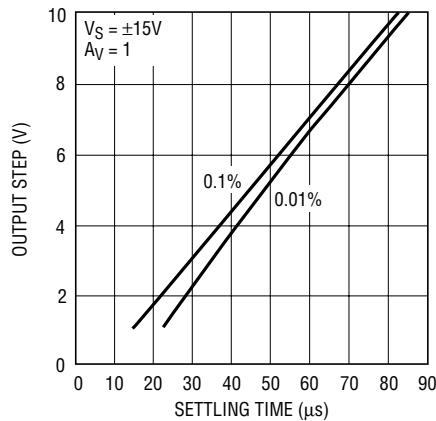

6011 G17

Settling Time vs Output Step

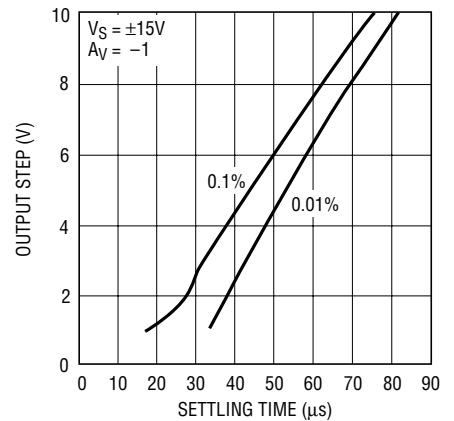

6011 G18

TYPICAL PERFORMANCE CHARACTERISTICS

Channel Separation vs Frequency

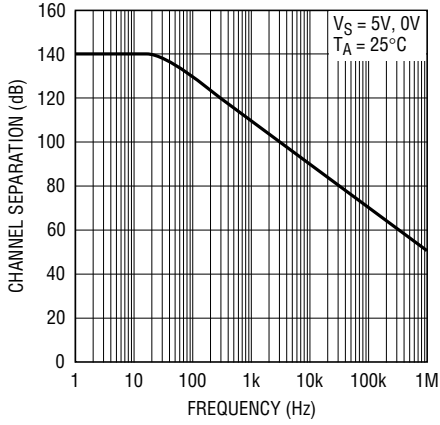

6011 G19

CMRR vs Frequency

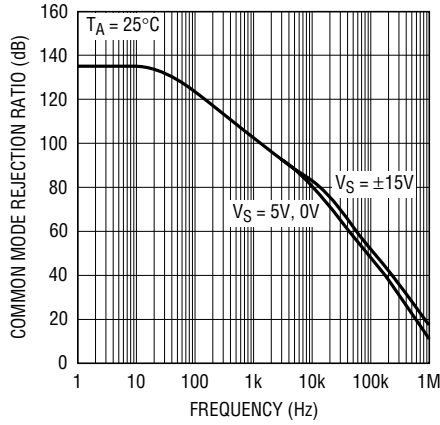

6011 G20

PSRR vs Frequency

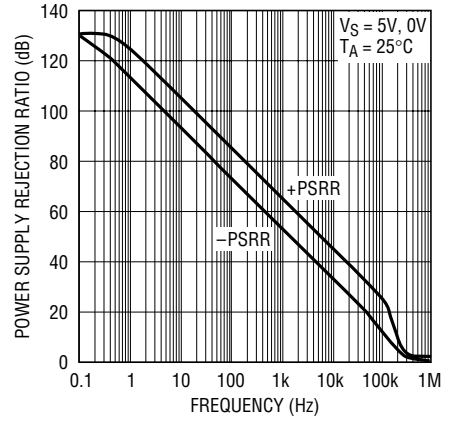

6011 G21

Output Impedance vs Frequency

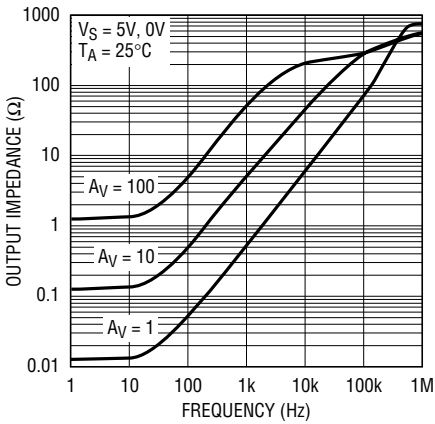

6011 G22

Open-Loop Gain vs Frequency

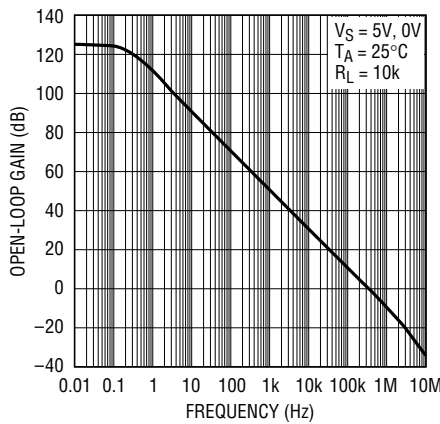

6011 G23

Gain and Phase vs Frequency

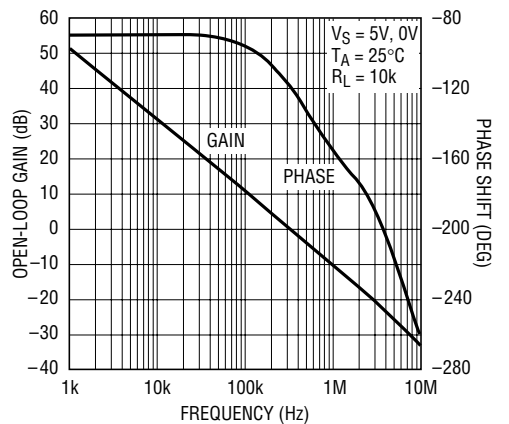

6011 G24

Gain vs Frequency, AV = 1

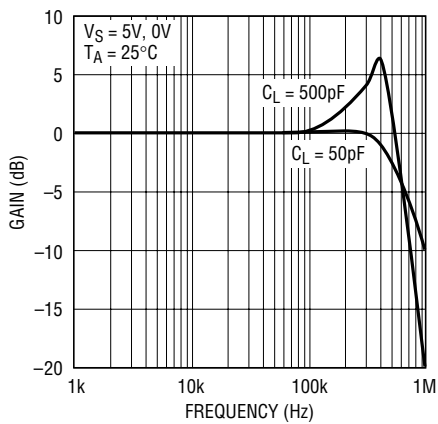

6011 G25

Gain vs Frequency, AV = -1

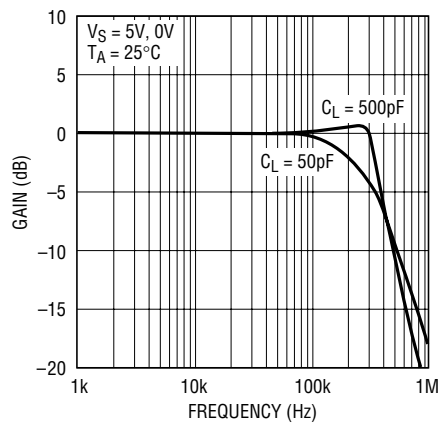

6011 G26

TYPICAL PERFORMANCE CHARACTERISTICS

Small-Signal Transient Response

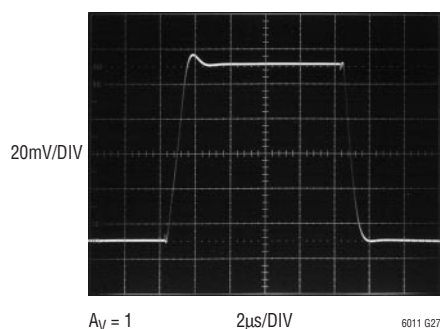

Large-Signal Transient Response

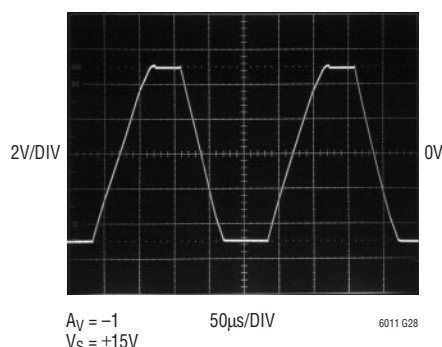

Rail-to-Rail Output Swing

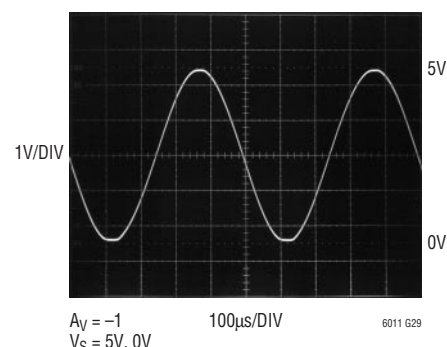

APPLICATIONS INFORMATION

Preserving Input Precision

Preserving the input accuracy of the LT6011 requires that the applications circuit and PC board layout do not introduce errors comparable to or greater than the 25µV typical offset of the amplifiers. Temperature differentials across the input connections can generate thermocouple voltages of 10's of microvolts so the connections to the input leads should be short, close together and away from heat dissipating components. Air currents across the board can also generate temperature differentials.

The extremely low input bias currents (150pA typical) allow high accuracy to be maintained with high impedance sources and feedback resistors. The LT6011 low input bias currents are obtained by a cancellation circuit on-chip. This causes the resulting I_{B^+} and I_{B^-} to be uncorrelated, as implied by the I_{OS} specification being comparable to I_B . Do not try to balance the input resistances in each input lead; instead keep the resistance at either input as low as possible for maximum accuracy.

Leakage currents on the PC board can be higher than the LT6011's input bias current. For example, 10GΩ of leakage between a 15V supply lead and an input lead will generate 1.5nA! Surround the input leads with a guard ring driven to the same potential as the input common mode to avoid excessive leakage in high impedance applications.

Input Protection

The LT6011 features on-chip back-to-back diodes between the input devices, along with 500Ω resistors in series with

either input. This internal protection limits the input current to approximately 10mA (the maximum allowed) for a 10V differential input voltage. Use additional external series resistors to limit the input current to 10mA in applications where differential inputs of more than 10V are expected. For example, a 1k resistor in series with each input provides protection against 30V differential voltage.

Input Common Mode Range

The LT6011 output is able to swing close to each power supply rail (rail-to-rail out), but the input stage is limited to operating between $V^- + 1V$ and $V^+ - 1.2V$. Exceeding this common mode range will cause the gain to drop to zero, however, no phase reversal will occur.

Total Input Noise

The LT6011 amplifier contributes negligible noise to the system when driven by sensors (sources) with impedance between 20kΩ and 1MΩ. Throughout this range, total input noise is dominated by the $4kTR_S$ noise of the source. If the source impedance is less than 20kΩ, the input voltage noise of the amplifier starts to contribute with a minimum noise of 14nV/√Hz for very low source impedance. If the source impedance is more than 1MΩ, the input current noise of the amplifier, multiplied by this high impedance, starts to contribute and eventually dominate. Total input noise spectral density can be calculated as:

$$V_{n(TOTAL)} = \sqrt{e_n^2 + 4kTR_S + (i_n R_S)^2}$$

APPLICATIONS INFORMATION

where $e_n = 14\text{nV}/\sqrt{\text{Hz}}$, $i_n = 0.1\text{pA}/\sqrt{\text{Hz}}$ and R_S is the total impedance at the input, including the source impedance.

Capacitive Loads

The LT6011 can drive capacitive loads up to 500pF in unity gain. The capacitive load driving capability increases as the amplifier is used in higher gain configurations. A small series resistance between the output and the load further increases the amount of capacitance that the amplifier can drive.

Rail-to-Rail Operation

The LT6011 outputs can swing to within millivolts of either supply rail, but the inputs can not. However, for most op amp configurations, the inputs need to swing less than the outputs. Figure 1 shows the basic op amp configurations, lists what happens to the op amp inputs and specifies whether or not the op amp must have rail-to-rail inputs. Select a rail-to-rail input op amp only when really necessary, because the input precision specifications are usually inferior.

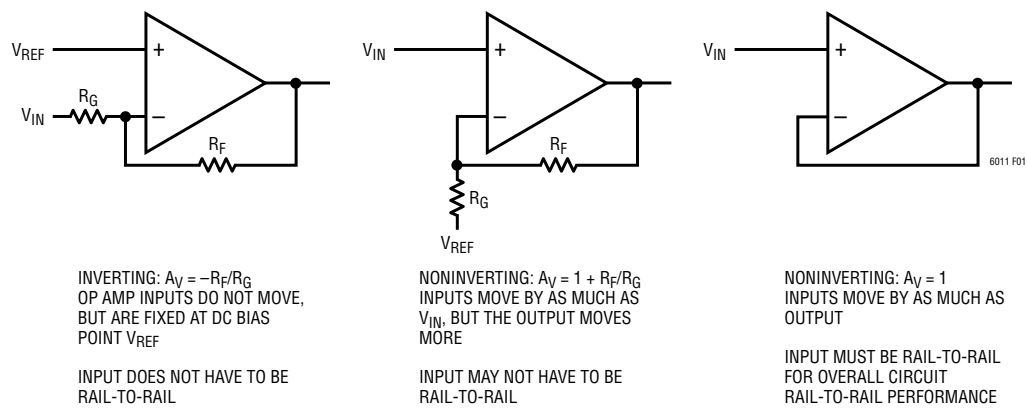
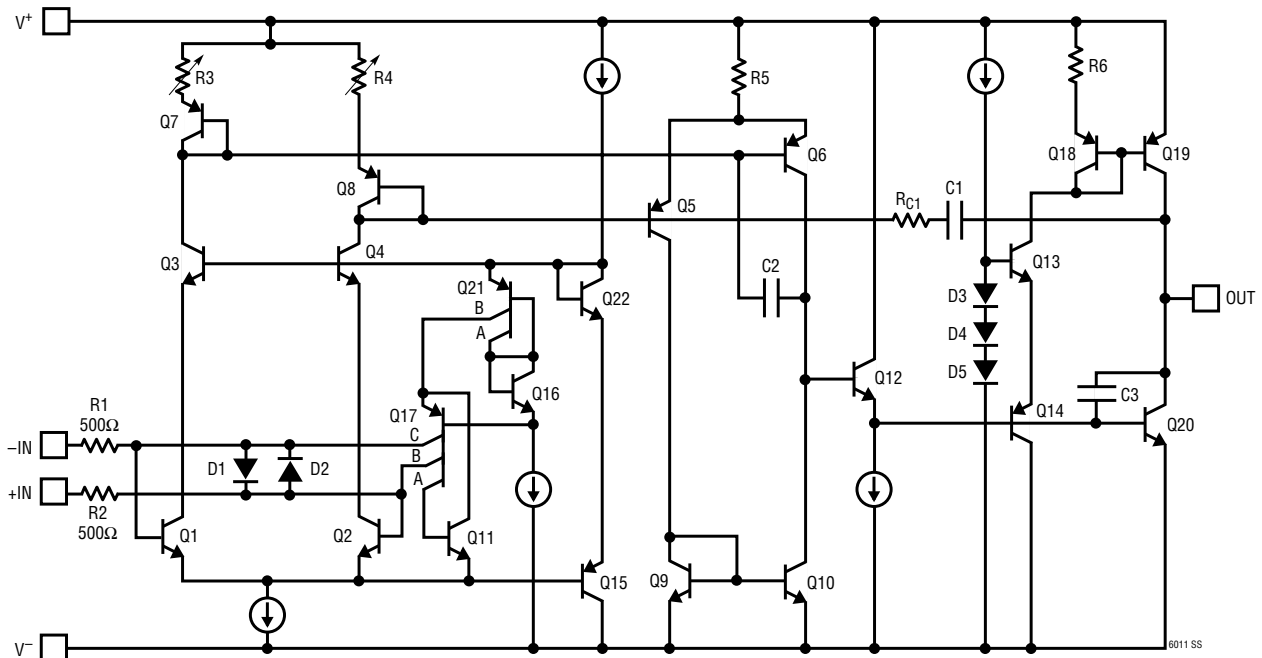

Figure 1. Some Op Amp Configurations Do Not Require Rail-to-Rail Inputs to Achieve Rail-to-Rail Outputs

SIMPLIFIED SCHEMATIC



6011f

PACKAGE DESCRIPTION

DD Package 8-Lead Plastic DFN (3mm × 3mm) (Reference LTC DWG # 05-08-1698)

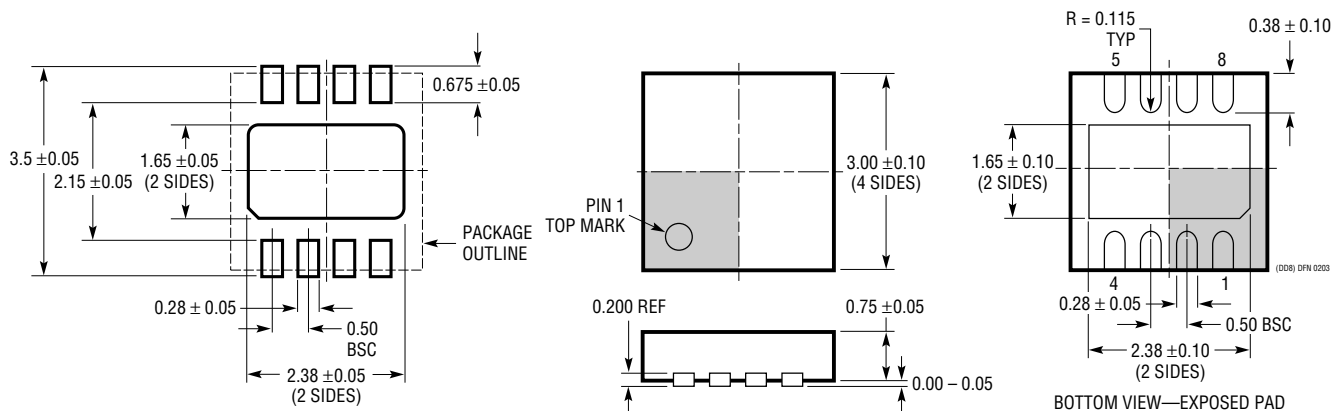

RECOMMENDED SOLDER PAD PITCH AND DIMENSIONS

NOTE:

1. DRAWING TO BE MADE A JEDEC PACKAGE OUTLINE M0-229 VARIATION OF (WEED-1)
2. ALL DIMENSIONS ARE IN MILLIMETERS
3. DIMENSIONS OF EXPOSED PAD ON BOTTOM OF PACKAGE DO NOT INCLUDE MOLD FLASH. MOLD FLASH, IF PRESENT, SHALL NOT EXCEED 0.15mm ON ANY SIDE
4. EXPOSED PAD SHALL BE SOLDER PLATED

S8 Package 8-Lead Plastic Small Outline (Narrow .150 Inch) (Reference LTC DWG # 05-08-1610)

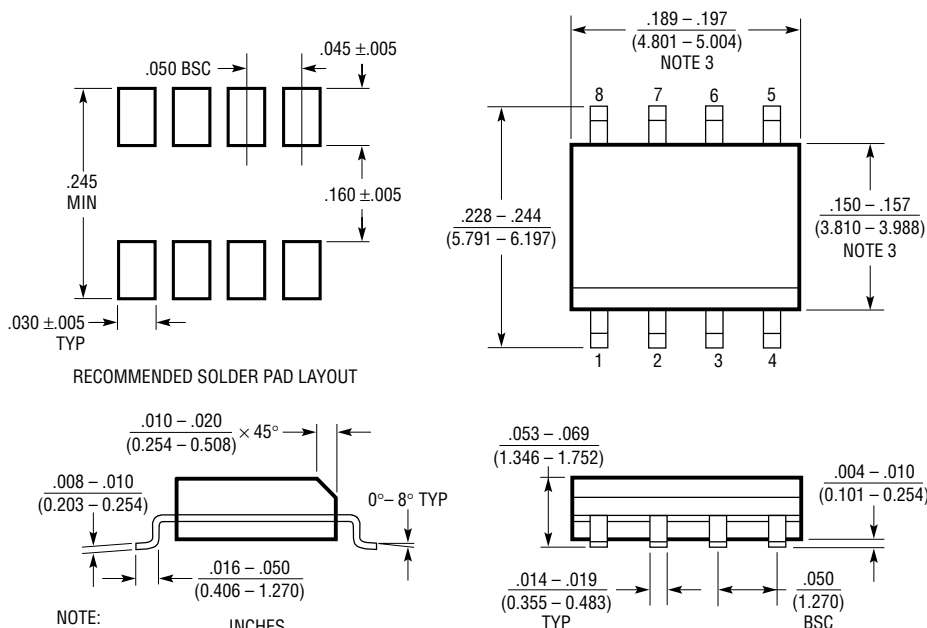

- NOTE:
1. DIMENSIONS IN $\frac{\text{INCHES}}{\text{MILLIMETERS}}$
 2. DRAWING NOT TO SCALE
 3. THESE DIMENSIONS DO NOT INCLUDE MOLD FLASH OR PROTRUSIONS. MOLD FLASH OR PROTRUSIONS SHALL NOT EXCEED .006" (0.15mm)

S08 0303

TYPICAL APPLICATION

Low Power Hall Sensor Amplifier

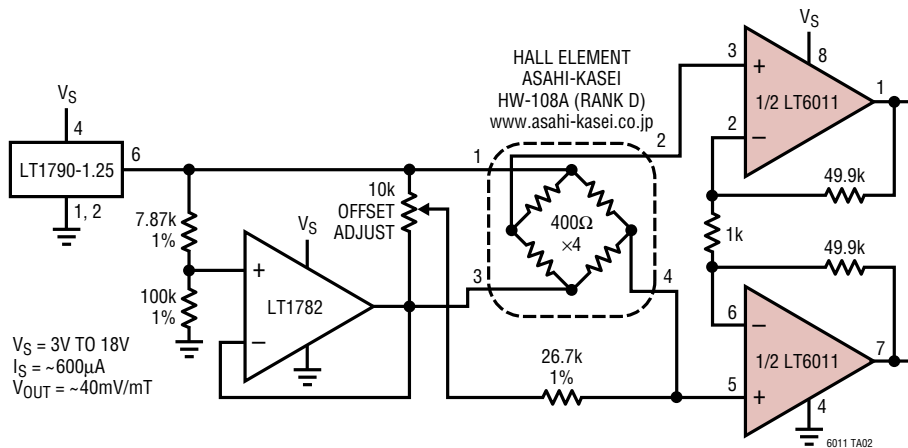

RELATED PARTS

PART NUMBER	DESCRIPTION	COMMENTS
LT1112	Dual Low Power, Picoamp Input Precision Op Amp	250pA Input Bias Current
LT1880	Rail-to-Rail Output, Picoamp Input Precision Op Amp	SOT-23
LT1881	Dual Rail-to-Rail Output, Picoamp Input Precision Op Amp	C _{LOAD} Up to 1000pF
LT1884	Dual Rail-to-Rail Output, Picoamp Input Precision Op Amp	9.5nV/√Hz Input Noise